



# CE EMC TEST REPORT

## (EN 50155 & EN 50121-3-2)

**REPORT NO.:** CE141111C02-1

**TEST MODEL:** SPC-2845

**SERIES MODEL:** Vecow SPC Series, SPC-2145, SPC-2845-W4,  
SPC-2845X, SPC-2845R, SPC-2845D,  
SPC-XXXXXXXXXX ("X" can be 0-9, A-Z or blank for  
marketing purpose)

**RECEIVED:** Nov. 11, 2014

**TESTED:** Nov. 20, 2014 ~ Jan. 07, 2015

**ISSUED:** Jan. 09, 2015

**APPLICANT:** Vecow Co., Ltd.

**ADDRESS:** 12F., No. 111, Zhongcheng Rd., Tucheng Dist., New  
Taipei City 23674 Taiwan (R. O. C.)

**ISSUED BY:** Bureau Veritas Consumer Products Services (H.K.)  
Ltd., Taoyuan Branch

**LAB ADDRESS:** No. 47-2, 14th Ling, Chia Pau Vil., Lin Kou Dist., New  
Taipei City, Taiwan, R.O.C.

**TEST LOCATION:** No. 19, Hwa Ya 2nd Rd, Wen Hwa Tsuen, Kwei Shan  
Hsiang, Taoyuan Hsien 333, Taiwan, R.O.C.

This report is for your exclusive use. Any copying or replication of this report to or for any other person or entity, or use of our name or trademark, is permitted only with our prior written permission. This report sets forth our findings solely with respect to the test samples identified herein. The results set forth in this report are not indicative or representative of the quality or characteristics of the lot from which a test sample was taken or any similar or identical product unless specifically and expressly noted. Our report includes all of the tests requested by you and the results thereof based upon the information that you provided to us. You have 60 days from date of issuance of this report to notify us of any material error or omission caused by our negligence, provided, however, that such notice shall be in writing and shall specifically address the issue you wish to raise. A failure to raise such issue within the prescribed time shall constitute your unqualified acceptance of the completeness of this report, the tests conducted and the correctness of the report contents. Unless specific mention, the uncertainty of measurement has been explicitly taken into account to declare the compliance or non-compliance to the specification.

The report must not be used by the client to claim product certification, approval, or endorsement by any government agencies.

## Table of Contents

RELEASE CONTROL RECORD.....	4
1 CERTIFICATION .....	5
2 SUMMARY OF TEST RESULTS .....	6
2.1 MEASUREMENT UNCERTAINTY .....	6
3 GENERAL INFORMATION.....	7
3.1 GENERAL DESCRIPTION OF EUT .....	7
3.2 DESCRIPTION OF TEST MODES .....	8
3.3 GENERAL DESCRIPTION OF THE APPLIED STANDARD .....	8
3.4 DESCRIPTION OF SUPPORT UNITS .....	9
3.5 CONFIGURATION OF SYSTEM UNDER TEST .....	11
4 EMISSION TEST .....	16
4.1 CONDUCTED EMISSION MEASUREMENT .....	16
4.1.1 LIMITS OF CONDUCTED EMISSION MEASUREMENT.....	16
4.1.2 TEST INSTRUMENTS .....	17
4.1.3 TEST PROCEDURE .....	17
4.1.4 DEVIATION FROM TEST STANDARD .....	17
4.1.5 TEST SETUP .....	18
4.1.6 EUT OPERATING CONDITIONS .....	18
4.1.7 TEST RESULTS .....	19
4.2 RADIATED EMISSION MEASUREMENT FOR ENCLOSURE PORT .....	21
4.2.1 LIMITS OF ENCLOSURE PORT .....	21
4.2.2 TEST INSTRUMENTS .....	22
4.2.3 TEST PROCEDURE .....	23
4.2.4 DEVIATION FROM TEST STANDARD .....	23
4.2.5 TEST SETUP .....	24
4.2.6 EUT OPERATING CONDITIONS .....	24
4.2.7 TEST RESULTS .....	25
5 IMMUNITY TEST .....	27
5.1 GENERAL DESCRIPTION .....	27
5.2 GENERAL PERFORMANCE CRITERIA DESCRIPTION .....	28
5.3 EUT OPERATING CONDITION .....	28
5.4 ELECTROSTATIC DISCHARGE IMMUNITY TEST (ESD) .....	29
5.4.1 TEST SPECIFICATION .....	29
5.4.2 TEST INSTRUMENTS .....	29
5.4.3 TEST PROCEDURE .....	30
5.4.4 DEVIATION FROM TEST STANDARD .....	31
5.4.5 TEST SETUP .....	31
5.4.6 TEST RESULTS .....	32
5.5 RADIATED, RADIO-FREQUENCY, ELECTROMAGNETIC FIELD IMMUNITY TEST (RS).....	36

5.5.1	TEST SPECIFICATION .....	36
5.5.2	TEST INSTRUMENTS .....	36
5.5.3	TEST PROCEDURE .....	37
5.5.4	DEVIATION FROM TEST STANDARD .....	37
5.5.5	TEST SETUP .....	37
5.5.6	TEST RESULTS .....	38
5.6	ELECTRICAL FAST TRANSIENT (EFT) .....	39
5.6.1	TEST SPECIFICATION .....	39
5.6.2	TEST INSTRUMENT .....	39
5.6.3	TEST PROCEDURE .....	39
5.6.4	DEVIATION FROM TEST STANDARD .....	40
5.6.5	TEST SETUP .....	40
5.6.6	TEST RESULTS .....	41
5.7	SURGE IMMUNITY .....	42
5.7.1	TEST SPECIFICATION .....	42
5.7.2	TEST INSTRUMENT .....	42
5.7.3	TEST PROCEDURE .....	43
5.7.4	DEVIATION FROM TEST STANDARD .....	43
5.7.5	TEST SETUP .....	44
5.7.6	TEST RESULTS .....	44
5.8	CONDUCTED RADIO FREQUENCY DISTURBANCES (CS) .....	45
5.8.1	TEST SPECIFICATION .....	45
5.8.2	TEST INSTRUMENT .....	46
5.8.3	TEST PROCEDURE .....	47
5.8.4	DEVIATION FROM TEST STANDARD .....	47
5.8.5	TEST SETUP .....	48
5.8.6	TEST RESULTS .....	49
6	PHOTOGRAPHS OF THE TEST CONFIGURATION.....	50
7	INFORMATION ON THE TESTING LABORATORIES .....	56



A D T

## RELEASE CONTROL RECORD

ISSUE NO.	REASON FOR CHANGE	DATE ISSUED
CE141111C02-1	Original release.	Jan. 09, 2015

## 1 CERTIFICATION

**PRODUCT:** Ultra-Compact Embedded System

**BRAND:** Vecow

**TEST MODEL:** SPC-2845

**SERIES MODEL:** Vecow SPC Series, SPC-2145, SPC-2845-W4, SPC-2845X, SPC-2845R, SPC-2845D, SPC-XXXXXXXXXX ("X" can be 0-9, A-Z or blank for marketing purpose)

**APPLICANT:** Vecow Co., Ltd.

**TESTED:** Nov. 20, 2014 ~ Jan. 07, 2015

**TEST SAMPLE:** ENGINEERING SAMPLE

**STANDARD:** **EN 50155:2007 +AC:2010 +AC:2012, Clause 12.2.7 & 12.2.8**

**EN 50121-3-2:2006 +AC:2008**

EN 55011:2009 +A1:2010

EN 61000-4-2:2009

EN 61000-4-3:2006 +A1:2008 +A2:2010

EN 61000-4-4:2012

EN 61000-4-5:2006

EN 61000-4-6:2014

The above equipment (model: SPC-2845) has been tested by **Bureau Veritas Consumer Products Services (H.K.) Ltd., Taoyuan Branch**, and found compliance with the requirement of the above standards. The test record, data evaluation & Equipment Under Test (EUT) configurations represented herein are true and accurate accounts of the measurements of the sample's EMC characteristics under the conditions specified in this report.

PREPARED BY :  , DATE : Jan. 09, 2015  
Suntee Liu / Specialist

APPROVED BY :  , DATE : Jan. 09, 2015  
Ken Liu / Senior Manager

## 2 SUMMARY OF TEST RESULTS

The EUT has been tested according to the following specifications.

EMISSIONS			
Standard	Test Type	Result	Remarks
EN 55011:2009 +A1:2010	Auxiliary a.c. or d.c. power port	PASS	Meet the requirement of limit. Minimum passing margin is -47.05dB at 0.15000MHz.
	Enclosure port	PASS	Meet the requirement of limit. Minimum passing margin is -5.07dB at 770.00MHz.

IMMUNITY			
Standard	Test Type	Result	Remarks
EN 61000-4-2:2009	Electrostatic discharge immunity test	PASS	Meets the requirements of Performance Criterion B
EN 61000-4-3:2006 +A1:2008 +A2:2010	Radiated, radio-frequency, electromagnetic field immunity test	PASS	Meets the requirements of Performance Criterion A
EN 61000-4-4:2012	Electrical fast transient / burst immunity test	PASS	Meets the requirements of Performance Criterion A (Judged by manufacturer)
EN 61000-4-5:2006	Surge immunity test	PASS	Meets the requirements of Performance Criterion A
EN 61000-4-6:2014	Immunity to conducted disturbances, induced by radio-frequency fields	PASS	Meets the requirements of Performance Criterion A

### 2.1 MEASUREMENT UNCERTAINTY

Where relevant, the following measurement uncertainty levels have been estimated for tests performed on the EUT as specified in CISPR 16-4-2:

This uncertainty represents an expanded uncertainty expressed at approximately the 95% confidence level using a coverage factor of  $k=2$ .

Measurement	Frequency	Uncertainty
Conducted emission	150kHz ~ 30MHz	2.44dB
Radiated emission	30MHz ~ 1GHz	4.70dB

The listed uncertainties are the worst case uncertainty for the entire range of measurement. Please note that the uncertainty values are provided for informational purposes only and are not used in determining the PASS/FAIL results.

### 3 GENERAL INFORMATION

#### 3.1 GENERAL DESCRIPTION OF EUT

<b>PRODUCT</b>	Ultra-Compact Embedded System
<b>TEST MODEL</b>	SPC-2845
<b>SERIES MODEL</b>	Vecow SPC Series, SPC-2145, SPC-2845-W4, SPC-2845X, SPC-2845R, SPC-2845D, SPC-XXXXXXXXXX ("X" can be 0-9, A-Z or blank for marketing purpose)
<b>OPERATING SOFTWARE</b>	Win 7
<b>POWER SUPPLY</b>	12Vdc (adapter)
<b>DATA CABLE</b>	NA
<b>ACCESSORY DEVICE</b>	Adapter

**NOTE:**

1. The EUT uses following adapter.

Brand	Seasonic
Model	SSA-0601D-12
Input Power	100-240Vac, 2A, 50/60Hz
Output Power	+12Vdc, 5A, 60W Max
Power Line	1m DC cable with 1 core attached on adapter

2. All models are electrically identical, different model names are for marketing purpose. Model SPC-2845 is the representative for final test.

Brand	Model
Vecow	Vecow SPC Series
	SPC-2845
	SPC-2145
	SPC-2845-W4
	SPC-2845X
	SPC-2845R
	SPC-2845D
	SPC-XXXXXXXXXX ("X" can be 0-9, A-Z or blank for marketing purpose)

3. The above EUT information is declared by manufacturer and for more detailed feature description, please refer to the manufacturer's specifications or user's manual.

### 3.2 DESCRIPTION OF TEST MODES

Test modes are presented in the report as below.

Mode	Test Condition
Conducted emission test	
-	DVI 1920*1200@60Hz, LAN 1 1Gbps, LAN 2 1Gbps
Radiated emission test	
-	DVI 1920*1200@60Hz, LAN 1 1Gbps, LAN 2 1Gbps
Immunity tests	
-	DVI 1920*1200@60Hz, LAN 1 1Gbps, LAN 2 1Gbps

### 3.3 GENERAL DESCRIPTION OF THE APPLIED STANDARD

The EUT is a kind of railway application equipments, and according to the specification of the EUT declared by manufacturer, it must comply with the requirements of the following standards:

**EN 50155:2007 +AC:2010 +AC:2012, Clause 12.2.7 & 12.2.8**

**EN 50121-3-2:2006 +AC:2008**

EN 55011:2009 +A1:2010

EN 61000-4-2:2009

EN 61000-4-3:2006 +A1:2008 +A2:2010

EN 61000-4-4:2012

EN 61000-4-5:2006

EN 61000-4-6:2014

**Note:** The above EN basic standards are applied with latest version if manufacturer has no special requirement.

All tests have been performed and recorded as per the above standards.



### 3.4 DESCRIPTION OF SUPPORT UNITS

The EUT has been tested as an independent unit together with other necessary accessories or support units. The following support units or accessories were used to form a representative test configuration during the tests.

#### Emission tests:

ID	Product	Brand	Model No.	Serial No.	FCC ID	Remarks
A.	24" LCD MONITOR	DELL	U2410	CN082WXD-72872-0CR-06DL	FCC DoC Approved	-
B.	Keyboard	DELL	KB4021	CN-05V23T-71581-1AK-01Q2-A01	FCC DoC Approved	-
C.	MOUSE	DELL	MS111-P	CN-011D3V-71581-1CJ-0195	FCC DoC Approved	-
D.	EARPHONE	PHILIPS	HL145	NA	NA	-
E.	PRINTER	EPSON	T22	MEEZ070220	FCC DoC Approved	-
F.	External Hard Disk	WD	WDBACY5000ABL-01	WX51C12T6215	NA	-
G.	MODEM	ACEEX	1414V/3	0401008278	IFAXDM1414	-
H.	MODEM	ACEEX	1414V/3	0401008252	IFAXDM1414	-
I.	MODEM	ACEEX	1414V/3	0401008241	IFAXDM1414	-
J.	MODEM	ACEEX	1414V/3	0401008279	IFAXDM1414	-
K.	Notebook	DELL	Latitude E6420	HPFC5Q1	FCC DoC Approved	-
L.	Notebook	DELL	PP02X	W4TYK9CQCJ3K3KCBRXTRFWYRB	QDS-BRCM1005-D	-

#### Note:

1. All power cords of the above support units are non-shielded (1.8m).
2. Items K~L acted as communication partners to transfer data.

ID	Descriptions	Qty.	Length (m)	Shielding (Yes/No)	Cores (Qty.)	Remarks
1.	DVI	1	1.8	Y	2	Provided by manufacturer
2.	USB	1	1.8	Y	0	-
3.	USB	1	1.8	Y	0	-
4.	Earphone	1	1.2	N	0	-
5.	USB	1	1.8	Y	0	-
6.	USB	1	0.5	Y	0	-
7.	RS-232	3	1.2	Y	0	-
8.	RS-232	1	1.5	Y	0	-
9.	RJ45, Cat5e	2	10	N	0	Only for Radiated emission test
10.	RS-232	1	2	Y	0	-
11.	RJ45, Cat5e	2	10	Y	0	Only for Conducted emission test

Note: The core(s) is(are) originally attached to the cable(s).

### Immunity tests:

ID	Product	Brand	Model No.	Serial No.	FCC ID	Remarks
A.	24" LCD Monitor	DELL	2407WFPb	CN-0YY528-46633-76I-1E7S	FCC DoC Approved	-
B.	Keyboard	DELL	KB4021	CN-05V23T-71581-1AK-01KZ-A01	FCC DoC Approved	-
C.	MOUSE	DELL	MS111-P	CN-011D3V-71581-1CJ-093U	FCC DoC Approved	-
D.	Earphone	PHILIPS	SHM2100U	03	NA	-
E.	Hard Disk	ADATA	HV620	1E3620122277	NA	-
F.	Hard Disk	ADATA	HV620	1E3620122297	NA	-
G.	MODEM	ACEEX	1414V/3	0401008252	IFAXDM1414	-
H.	MODEM	ACEEX	1414V/3	0401008253	IFAXDM1414	-
I.	MODEM	ACEEX	1414V/3	0401008270	IFAXDM1414	-
J.	MODEM	ACEEX	1414V/3	0401008268	IFAXDM1414	-
K.	Notebook	Dell	E5420	55CD5S1	FCC DoC Approved	-
L.	Notebook	Dell	E5420	55CF4S1	FCC DoC Approved	-

Note:

1. All power cords of the above support units are non-shielded (1.8m).
2. Items K~L acted as communication partners to transfer data.

ID	Descriptions	Qty.	Length (m)	Shielding (Yes/No)	Cores (Qty.)	Remarks
1.	DVI	1	1.8	Y	2	Provided by manufacturer
2.	USB	1	1.8	Y	0	-
3.	USB	1	1.8	Y	0	-
4.	Earphone	1	1.9	N	0	-
5.	USB	1	0.3	Y	0	-
6.	USB	1	0.3	Y	0	-
7.	RS-232	4	1.6	Y	0	-
8.	RJ45, Cat5e	2	10	N	0	Only for ESD, Surge tests
9.	RJ45, Cat5e	2	10	Y	0	Only for RS, EFT, CS tests
10.	Ground	1	1.8	Y	0	Only for RS, EFT tests

Note: The core(s) is(are) originally attached to the cable(s).

### 3.5 CONFIGURATION OF SYSTEM UNDER TEST

Conducted emission test:

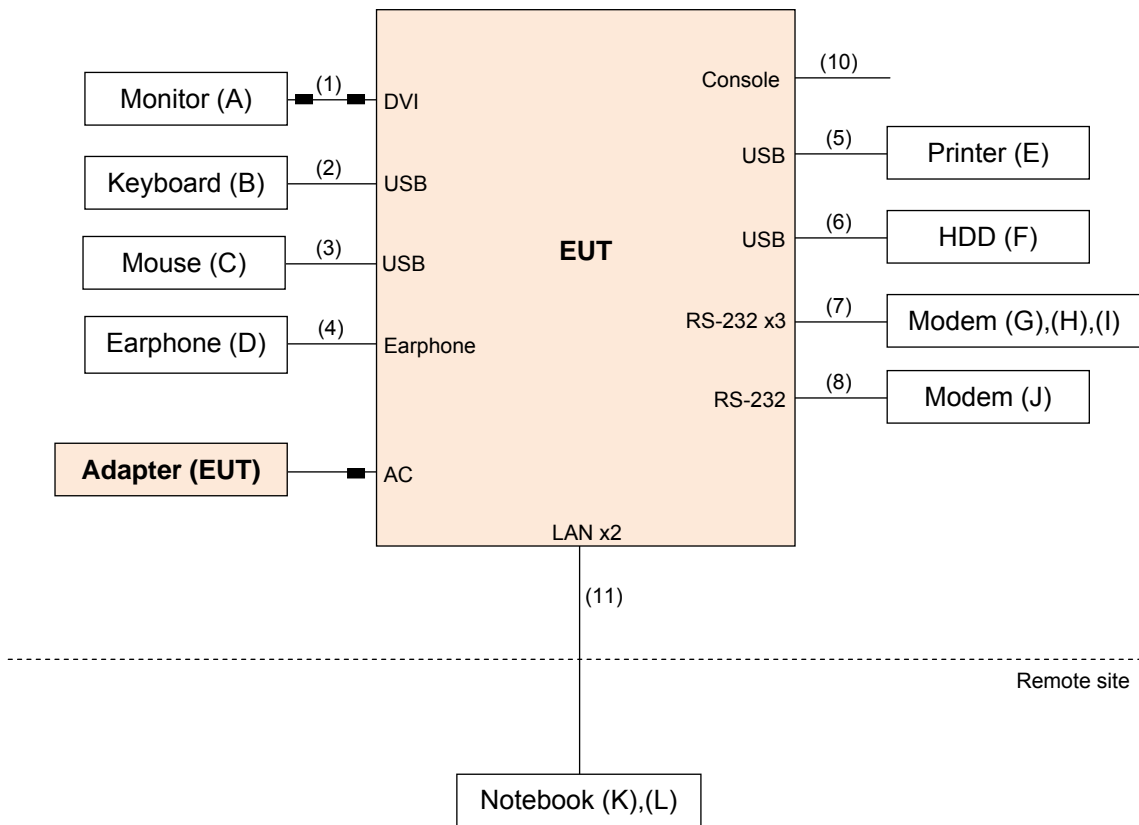

Radiated emission test:

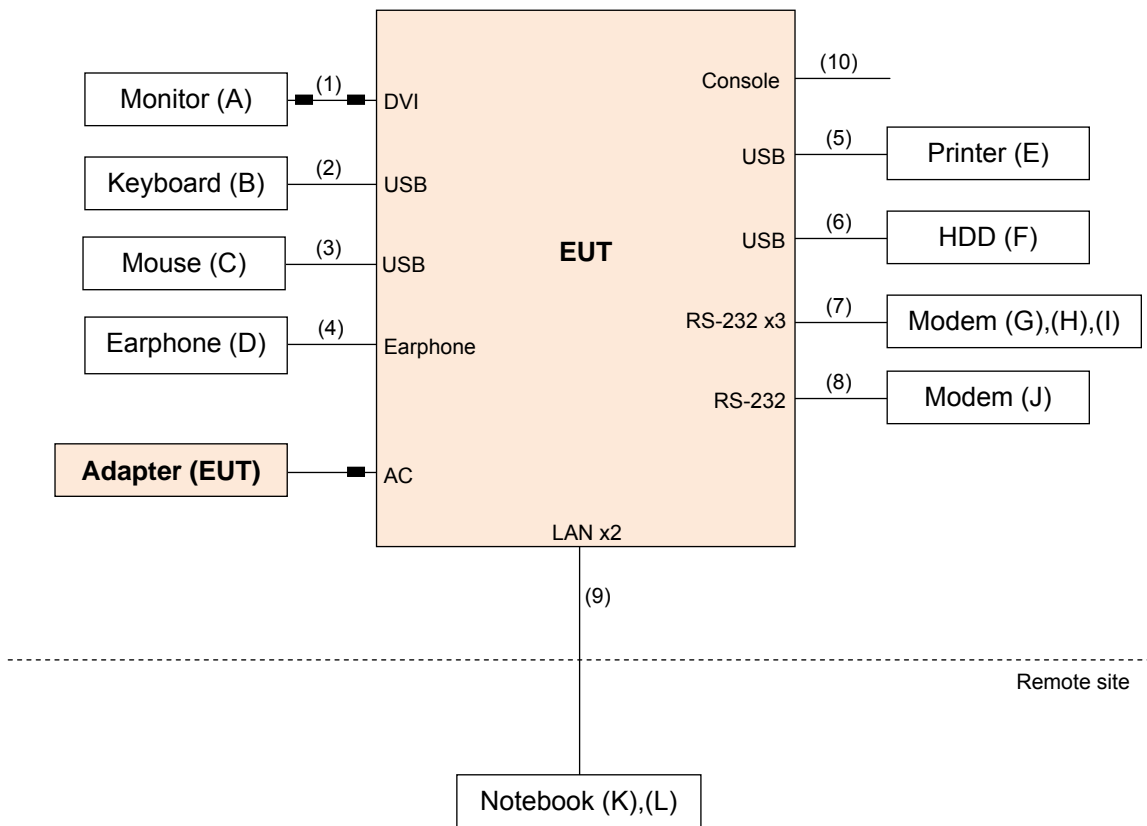

ESD, Surge tests:

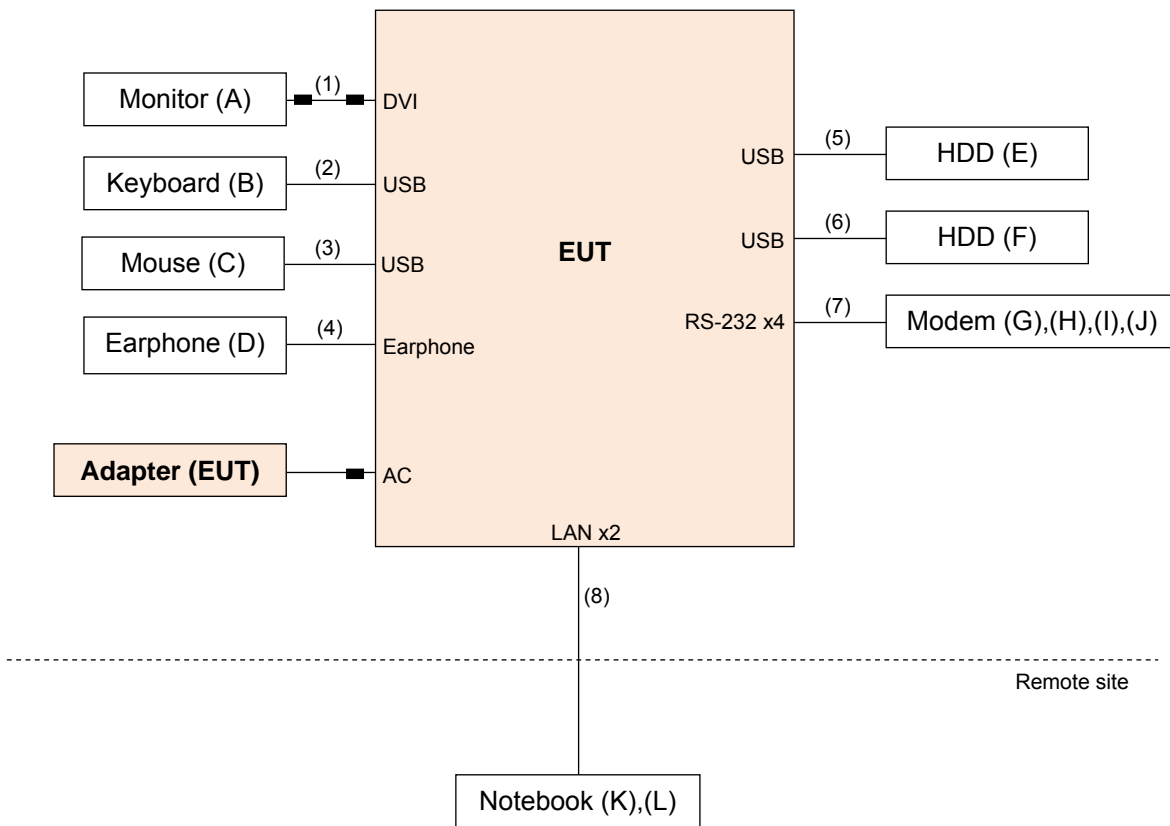

RS, EFT tests:

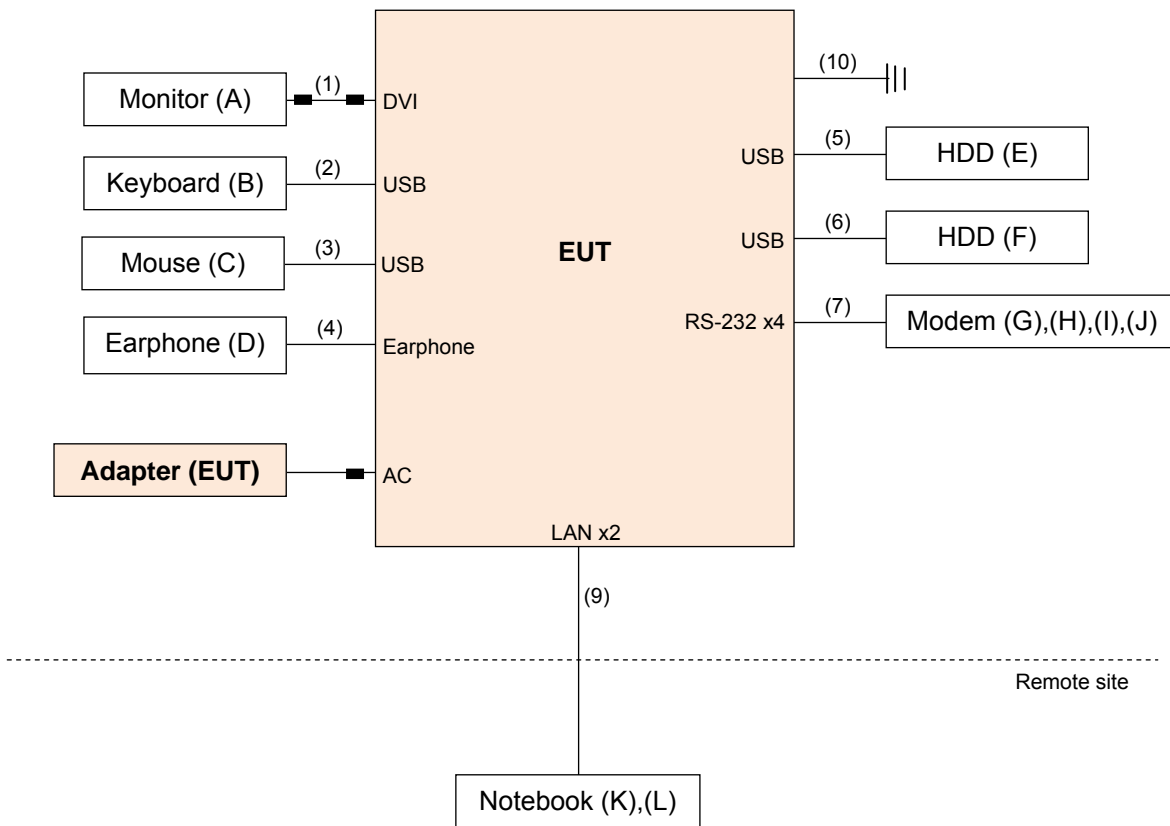

CS test:

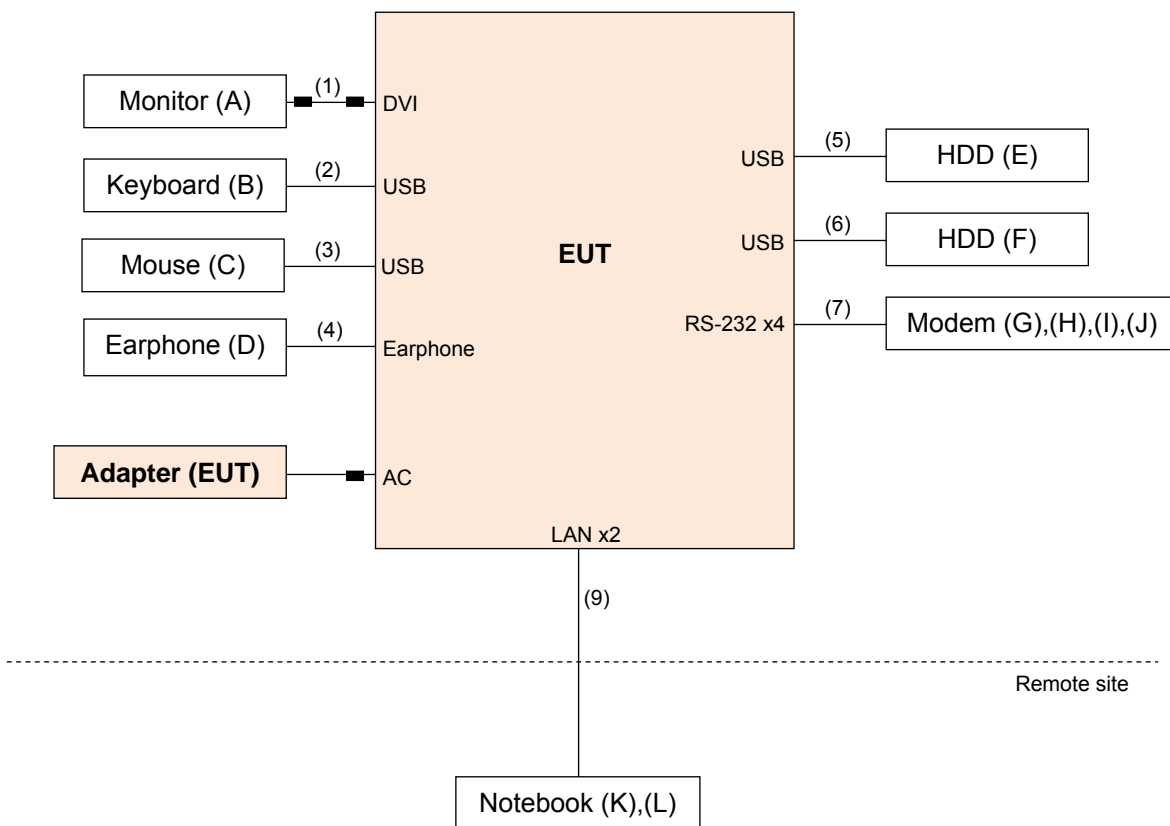

## 4 EMISSION TEST

### 4.1 CONDUCTED EMISSION MEASUREMENT

#### 4.1.1 LIMITS OF CONDUCTED EMISSION MEASUREMENT

##### TEST STANDARD: EN50121-3-2

Frequency (MHz)	Quasi-peak	Remarks
0.009-0.15	No Limit	See note 1 & 2
0.15-0.5	99	See note 3, 4 & 5
0.5-30	93	See note 3, 4 & 5

##### NOTE:

1. At present there are no limits for conducted emissions from 9 kHz to 150 kHz. Limiting conducted emissions from an apparatus will prevent excessive radiated emissions. Experience in this technique and the relationship between conducted and radiated emissions is necessary in order to progress this standard in the future.
2. 230 V AC power outlet ports for public use shall offer a power quality, which is sufficient for the use of intended equipment like PC and mobile telephone chargers. The harmonic distortion in differential and common mode shall be limited by a sine-filter to < 5 %. The burst and surge emissions of the outlet have to be limited to the levels of residential equipment according to EN 61000-6-1. AM radio receivers are not intended to be supplied by these power outlets.
3. Wherever applicable the method defined by EN 55011 is to be used. At present the existing method of measuring conducted emissions (EN 55011) has limitations in terms of voltage and current rating of coupling networks. In addition the method of measuring voltage has safety implications for testing high power systems. Limiting conducted emissions from apparatus connected to external cable systems will prevent excessive radiated emissions.
4. This requirement refers to the industrial limit values but considering they have been defined to protect radio and TV sets and as the objective is not the same here, the applicable limit for railway applications have been relaxed by 20 dB to be more representative of potential problems.
5. This requirement is not applicable to power ports which are connected to other dedicated, compatible ports.



#### 4.1.2 TEST INSTRUMENTS

Description & Manufacturer	Model No.	Serial No.	Cal. Date	Cal. Due
Test Receiver ROHDE & SCHWARZ	ESCS30	100288	Apr. 24, 2014	Apr. 23, 2015
RF signal cable Woken	5D-FB	Cable-HYCO2-01	Dec. 27, 2013	Dec. 26, 2014
LISN ROHDE & SCHWARZ (EUT)	ESH2-Z5	100100	Dec. 23, 2013	Dec. 22, 2014
LISN ROHDE & SCHWARZ (Peripheral)	ESH3-Z5	100312	Jul. 10, 2014	Jul. 09, 2015
Software ADT	BV ADT_Cond_ V7.3.7.3	NA	NA	NA

- Notes: 1. The calibration interval of the above test instruments is 12 months and the calibrations are traceable to NML/ROC and NIST/USA.  
 2. The test was performed in HwaYa Shielded Room 2.  
 3. The VCCI Site Registration No. is C-2047.

#### 4.1.3 TEST PROCEDURE

- a. The EUT was placed 0.4 meters from the conducting wall of the shielded room with EUT being connected to the power mains through a line impedance stabilization network (LISN). Other support units were connected to the power mains through another LISN. The two LISNs provide 50 Ohm/ 50uH of coupling impedance for the measuring instrument.
- b. Both lines of the power mains connected to the EUT were checked for maximum conducted interference.
- c. The frequency range from 150 kHz to 30 MHz was searched. Emission levels under Limit - 20dB was not recorded.

#### 4.1.4 DEVIATION FROM TEST STANDARD

No deviation.

#### 4.1.5 TEST SETUP

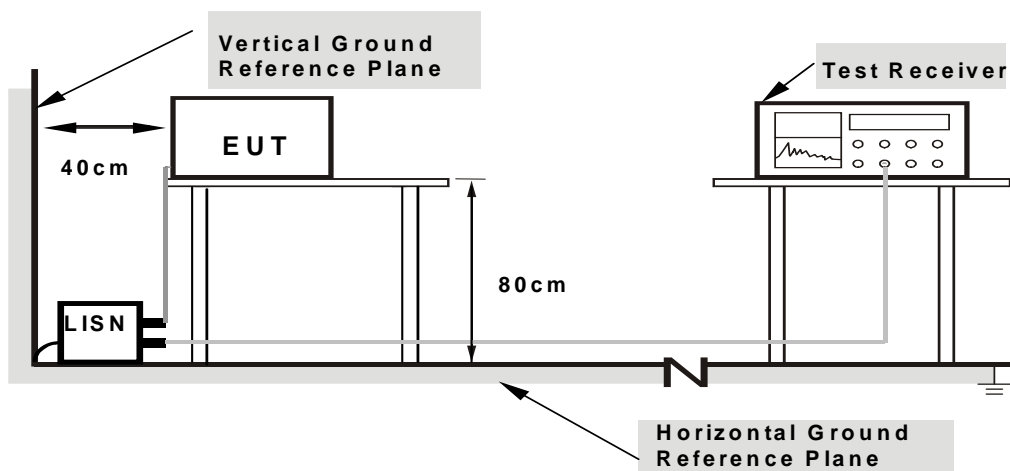

- Note:**
1. Support units were connected to second LISN.
  2. Both of LISNs (AMN) are 80 cm from EUT and at least 80 cm from other units and other metal planes

For the actual test configuration, please refer to the related item – Photographs of the Test Configuration.

#### 4.1.6 EUT OPERATING CONDITIONS

- a. EUT sent “H” patterns to monitor and monitor displayed them.
- b. EUT sent “H” patterns to printer and printer printed them.
- c. EUT sent “H” patterns to modems.
- d. EUT performed R/W function with HDD.
- e. EUT sent audio signal to earphone.
- f. EUT linked with notebooks through LAN.

### 4.1.7 TEST RESULTS

Frequency Range	150kHz ~ 30MHz	Detector Function & Bandwidth	Quasi-Peak (QP) / Average (AV), 9kHz
Input Power	230Vac · 50Hz	Environmental Conditions	23°C, 64%RH
Tested by	Scott Yang	Test Date	2014/11/21

Phase Of Power : Line (L)						
No	Frequency (MHz)	Correction Factor (dB)	Reading Value (dBuV)	Emission Level (dBuV)	Limit (dBuV)	Margin (dB)
			Q.P.	Q.P.	Q.P.	Q.P.
<b>1</b>	<b>0.15000</b>	<b>0.26</b>	<b>51.69</b>	<b>51.95</b>	<b>99.00</b>	<b>-47.05</b>
2	0.23203	0.28	41.44	41.72	99.00	-57.28
3	0.45859	0.30	31.22	31.52	99.00	-67.48
4	1.73047	0.35	24.10	24.45	93.00	-68.55
5	4.51953	0.44	27.71	28.15	93.00	-64.85
6	22.74609	0.56	37.15	37.71	93.00	-55.29

Remarks:

1. Q.P. and AV. are abbreviations of quasi-peak and average individually.
2. The emission levels of other frequencies were very low against the limit.
3. Margin value = Emission level – Limit value
4. Correction factor = Insertion loss + Cable loss
5. Emission Level = Correction Factor + Reading Value

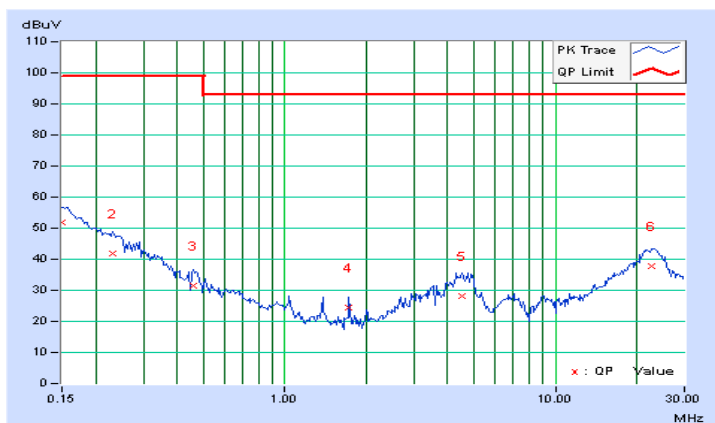

Frequency Range	150kHz ~ 30MHz	Detector Function & Bandwidth	Quasi-Peak (QP) / Average (AV), 9kHz
Input Power	230Vac · 50Hz	Environmental Conditions	23°C, 64%RH
Tested by	Scott Yang	Test Date	2014/11/21

Phase Of Power : Neutral (N)						
No	Frequency (MHz)	Correction Factor (dB)	Reading Value (dBuV)	Emission Level (dBuV)	Limit (dBuV)	Margin (dB)
			Q.P.	Q.P.	Q.P.	Q.P.
1	0.15391	0.27	51.24	51.51	99.00	-47.49
2	0.20469	0.28	44.24	44.52	99.00	-54.48
3	0.47813	0.31	29.45	29.76	99.00	-69.24
4	1.38672	0.35	24.68	25.03	93.00	-67.97
5	4.70313	0.45	31.57	32.02	93.00	-60.98
6	22.33203	0.61	35.93	36.54	93.00	-56.46

Remarks:

1. Q.P. and AV. are abbreviations of quasi-peak and average individually.
2. The emission levels of other frequencies were very low against the limit.
3. Margin value = Emission level – Limit value
4. Correction factor = Insertion loss + Cable loss
5. Emission Level = Correction Factor + Reading Value

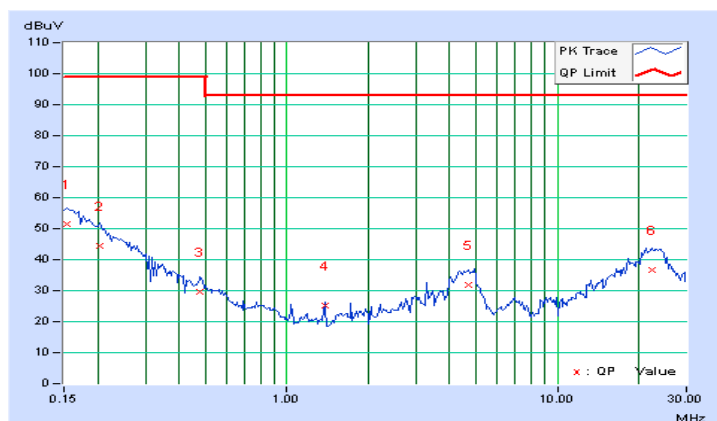

## 4.2 RADIATED EMISSION MEASUREMENT FOR ENCLOSURE PORT

### 4.2.1 LIMITS OF ENCLOSURE PORT

#### TEST STANDARD: EN 50121-3-2

Port	Test Specification		Basic Standard	Remarks
			Test set-up	
Enclosure	30 MHz ~ 230 MHz	40 dB $\mu$ V/m quasi-peak	EN 55011	Note 1 & 2
	230 MHz ~ 1 GHz	47 dB $\mu$ V/m quasi-peak		Note 1 & 2

**NOTE:** 1. Measurement distance is 10 m. A measurement distance of 3 m may be used with the limit increased by 10 dB.

2. Traction converters and auxiliary converters over 50 kVA need not be tested individually but when the vehicle is tested as a whole in accordance with EN 50121-3-1.

## 4.2.2 TEST INSTRUMENTS

Description & Manufacturer	Model No.	Serial No.	Cal. Date	Cal. Due
Test Receiver ROHDE & SCHWARZ (V)	ESR-7	101240	Sep. 29, 2014	Sep. 28, 2015
Test Receiver ROHDE & SCHWARZ (H)	ESR-7	101264	Nov. 29, 2013	Nov. 28, 2014
BILOG Antenna SCHWARZBECK (V)	VULB9168	9168-148	Feb. 25, 2014	Feb. 24, 2015
BILOG Antenna SCHWARZBECK (H)	VULB9168	9168-149	Feb. 25, 2014	Feb. 24, 2015
Preamplifier Agilent (V)	8447D	2944A10636	Oct. 18, 2014	Oct. 17, 2015
Preamplifier Agilent (H)	8447D	2944A10637	Oct. 18, 2014	Oct. 17, 2015
Preamplifier Agilent	8449B	3008A01959	Oct. 18, 2014	Oct. 17, 2015
RF signal cable Woken (V)	8D-FB	Cable-CH(H)-01	Oct. 25, 2014	Oct. 24, 2015
RF signal cable Woken (H)	8D-FB	Cable-CH(V)-01	Oct. 25, 2014	Oct. 24, 2015
Software BV ADT	BV ADT_Radiated_ V 8.7.07	NA	NA	NA
Antenna Tower (V)	MFA-440	9707	NA	NA
Antenna Tower (H)	MFA-440	970705	NA	NA
Turn Table	DS430	50303	NA	NA
Controller (V)	MF7802	074	NA	NA
Controller (H)	MF7802	08093	NA	NA

- Notes: 1. The calibration interval of the above test instruments is 12 months and the calibrations are traceable to NML/ROC and NIST/USA.
2. The test was performed in HwaYa Chamber 1.
3. The FCC Site Registration No. is 477732.
4. The IC Site Registration No. is IC 7450F-1.
5. The VCCI Site Registration No. is R-1893.

### 4.2.3 TEST PROCEDURE

- a. The EUT was placed on the top of a rotating table 0.8 meters above the ground at a 10 meter semi-anechoic chamber room. The table was rotated 360 degrees to determine the position of the highest radiation.
- b. The EUT was set 10 meters away from the interference-receiving antenna, which was mounted on the top of a variable-height antenna tower.
- c. The height of antenna is varied from 1 meter to 4 meters above the ground to determine the maximum value of the field strength. Both horizontal and vertical polarizations of the antenna are set to make the measurement.
- d. For each suspected emission, the EUT was arranged to its worst case and then the antenna was tuned to heights from 1 meter to 4 meters and the rotatable table was turned from 0 degrees to 360 degrees to find the maximum reading.
- e. The test-receiver system was set to quasi-peak detect function and specified bandwidth with maximum hold mode when the test frequency is below 1GHz.

**NOTE:** The resolution bandwidth of test receiver/spectrum analyzer is 120kHz for Quasi-Peak (QP) detection at frequency below 1GHz.

### 4.2.4 DEVIATION FROM TEST STANDARD

No deviation.

### 4.2.5 TEST SETUP

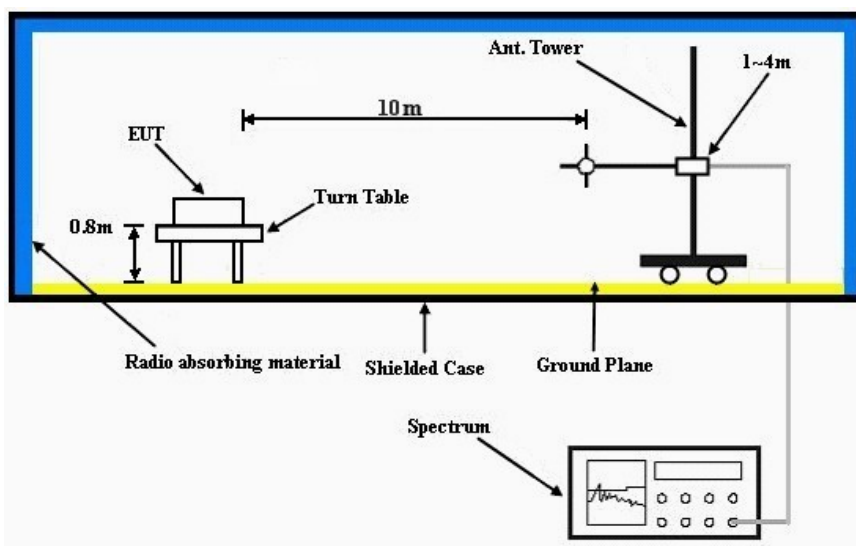

For the actual test configuration, please refer to the related item – Photographs of the Test Configuration.

### 4.2.6 EUT OPERATING CONDITIONS

Same as 4.1.6.



### 4.2.7 TEST RESULTS

Frequency Range	30MHz ~ 1GHz	Detector Function & Bandwidth	Quasi-Peak (QP), 120kHz
Input Power	230Vac, 50Hz	Environmental Conditions	23°C, 64%RH
Tested by	Scott Yang	Test Date	2014/11/20

Antenna Polarity & Test Distance : Horizontal at 10 m								
No	Frequency (MHz)	Emission Level (dBuV/m)	Limit (dBuV/m)	Margin (dB)	Antenna Height (m)	Table Angle (Degree)	Raw Value (dBuV)	Correction Factor (dB/m)
1	112.84	26.49 QP	40.00	-13.51	4.00 H	132	43.54	-17.05
2	160.91	27.49 QP	40.00	-12.51	3.50 H	35	41.23	-13.74
3	214.41	29.53 QP	40.00	-10.47	4.00 H	332	45.58	-16.05
4	248.26	30.49 QP	47.00	-16.51	3.00 H	134	44.47	-13.98
5	410.36	32.23 QP	47.00	-14.77	2.50 H	322	41.23	-9.00
6	770.00	38.46 QP	47.00	-8.54	4.00 H	270	40.08	-1.62

Remarks:

1. Emission Level(dBuV/m) = Raw Value(dBuV) + Correction Factor(dB/m)
2. Correction Factor(dB/m) = Antenna Factor (dB/m) + Cable Factor (dB) – Pre-Amplifier Factor (dB)
3. The other emission levels were very low against the limit.
4. Margin value = Emission level – Limit value

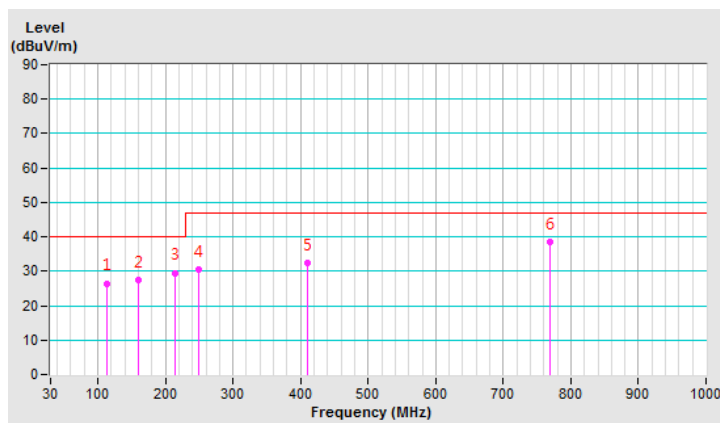

Frequency Range	30MHz ~ 1GHz	Detector Function & Bandwidth	Quasi-Peak (QP), 120kHz
Input Power	230Vac, 50Hz	Environmental Conditions	23°C, 64%RH
Tested by	Scott Yang	Test Date	2014/11/20

Antenna Polarity & Test Distance : Vertical at 10 m								
No	Frequency (MHz)	Emission Level (dBuV/m)	Limit (dBuV/m)	Margin (dB)	Antenna Height (m)	Table Angle (Degree)	Raw Value (dBuV)	Correction Factor (dB/m)
1	38.44	31.79 QP	40.00	-8.21	1.50 V	60	46.60	-14.81
2	67.69	31.55 QP	40.00	-8.45	2.00 V	72	47.16	-15.61
3	149.46	30.52 QP	40.00	-9.48	1.00 V	296	44.00	-13.48
4	198.74	30.41 QP	40.00	-9.59	1.00 V	261	46.29	-15.88
5	369.08	32.51 QP	47.00	-14.49	1.00 V	119	41.80	-9.29
<b>6</b>	<b>770.00</b>	<b>41.93 QP</b>	<b>47.00</b>	<b>-5.07</b>	<b>2.50 V</b>	<b>307</b>	<b>42.91</b>	<b>-0.98</b>

Remarks:

1. Emission Level(dBuV/m) = Raw Value(dBuV) + Correction Factor(dB/m)
2. Correction Factor(dB/m) = Antenna Factor (dB/m) + Cable Factor (dB) – Pre-Amplifier Factor (dB)
3. The other emission levels were very low against the limit.
4. Margin value = Emission level – Limit value

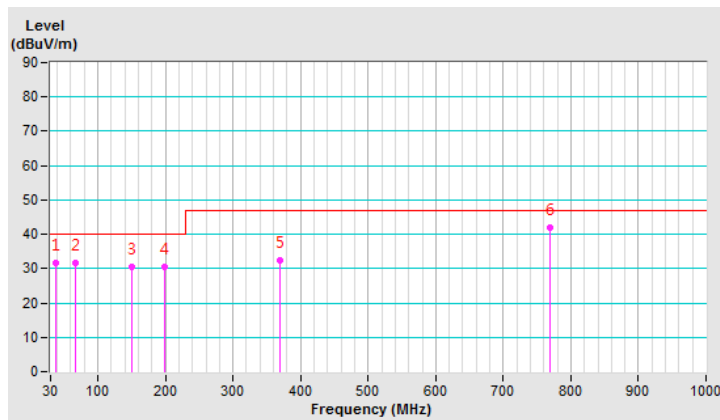

## 5 IMMUNITY TEST

### 5.1 GENERAL DESCRIPTION

Product standard	EN 50121-3-2	
Basic standard, Specification requirement and Performance criteria	EN 61000-4-2	Electrostatic Discharge – ESD: 8 kV air discharge, 6 kV contact discharge, Performance Criterion B
	EN 61000-4-3	Radio-Frequency Electromagnetic Field Susceptibility Test – RS: 80-1000 MHz, 20 V/m, 80% AM (1 kHz), <sup>1</sup> 800-1000 MHz, 20 V/m, 80% AM (1 kHz), 1400-2100 MHz, 10 V/m, 80% AM (1 kHz), 2100-2500 MHz, 5 V/m, 80% AM (1 kHz), Performance Criterion A
	EN 61000-4-4	Electrical Fast Transient/Burst - EFT, Power line: 2kV, Signal line: 2kV, Performance Criterion A
	EN 61000-4-5	Surge Immunity Test: 1.2/50 us Open Circuit Voltage, Power Line: line to line 1 kV, line to ground 2 kV Performance Criterion B
	EN 61000-4-6	Conducted Radio Frequency Disturbances Test – CS: 0.15 ~ 80 MHz, 10Vrms, 80% AM, 1kHz, Performance Criterion A

**NOTE 1:** This limit applies to equipment mounted in the passenger compartments, drivers cab or external to the rolling stock (roof, underframe). For equipment mounted in all other areas a severity level of 10 V/m may be used.

## 5.2 GENERAL PERFORMANCE CRITERIA DESCRIPTION

According to EN 50121-1 standard, the following describes the general performance criteria:

A functional description and a definition of performance criteria, during or as a consequence of the EMC testing, shall be provided by the manufacturer and noted in the test report, based on the following criteria:

<b>CRITERION A</b>	The apparatus shall continue to operate as intended during and after the test. No degradation of performance or loss of function is allowed below a performance level specified by the manufacturer, when the apparatus is used as intended. The performance level may be replaced by a permissible loss of performance. If the minimum performance level or the permissible performance loss is not specified by the manufacturer, either of these may be derived from the product description and documentation, and from what the user may reasonably expect from the apparatus if used as intended.
<b>CRITERION B</b>	The apparatus shall continue to operate as intended after the test. No degradation of performance or loss of function is allowed below a performance level specified by the manufacturer, when the apparatus is used as intended. The performance level may be replaced by a permissible loss of performance. During the test, degradation of performance is however allowed. No change of actual operating state or stored data is allowed. If the minimum performance level or the permissible performance loss is not specified by the manufacturer, either of these may be derived from the product description and documentation, and from what the user may reasonably expect from the apparatus if used as intended.
<b>CRITERION C</b>	Temporary loss of function is allowed, provided the function is self-recoverable or can be restored by the operation of the controls.

## 5.3 EUT OPERATING CONDITION

- a. EUT sent "H" patterns to monitor and monitor displayed them.
- b. EUT sent "H" patterns to modems.
- c. EUT performed R/W function with HDDs.
- d. EUT sent audio signal to earphone.
- e. EUT linked with notebooks through LAN.

## 5.4 ELECTROSTATIC DISCHARGE IMMUNITY TEST (ESD)

### 5.4.1 TEST SPECIFICATION

<b>Basic Standard:</b>	EN 61000-4-2
<b>Discharge Impedance:</b>	330 ohm / 150 pF
<b>Discharge Voltage:</b>	Air Discharge: 2, 4, 8 kV (Direct) Contact Discharge: 2, 4, 6 kV (Direct/Indirect)
<b>Polarity:</b>	Positive & Negative
<b>Number of Discharge:</b>	Minimum 20 times at each test point
<b>Discharge Mode:</b>	Single Discharge
<b>Discharge Period:</b>	1 second minimum

### 5.4.2 TEST INSTRUMENTS

Description & Manufacturer	Model No.	Serial No.	Cal. Date	Cal. Due
Electronic Discharge Simulator (KeyTek)	MZ-151EC	0310225	Jun. 09, 2014	Jun. 08, 2015

- Notes: 1. The test was performed in Hwa Ya ESD Room 4.  
2. The calibration interval of the above test instruments is 12 months and the calibrations are traceable to NML/ROC and NIST/USA.

### 5.4.3 TEST PROCEDURE

The discharges shall be applied in two ways:

a. Contact discharges to the conductive surfaces and coupling planes:

The EUT shall be exposed to at least 200 discharges, 100 each at negative and positive polarity, at a minimum of four test points. One of the test points shall be subjected to at least 50 indirect discharges to the center of the front edge of the horizontal coupling plane. The remaining three test points shall each receive at least 50 direct contact discharges. If no direct contact test points are available, then at least 200 indirect discharges shall be applied in the indirect mode. Test shall be performed at a maximum repetition rate of one discharge per second.

b. Air discharges at slots and apertures and insulating surfaces:

On those parts of the EUT where it is not possible to perform contact discharge testing, the equipment should be investigated to identify user accessible points where breakdown may occur. Such points are tested using the air discharge method. This investigation should be restricted to those area normally handled by the user. A minimum of 10 single air discharges shall be applied to the selected test point for each such area.

The basic test procedure was in accordance with EN 61000-4-2:

- a. Electrostatic discharges were applied only to those points and surfaces of the EUT that are accessible to users during normal operation.
- b. The test was performed with at least ten single discharges on the pre-selected points in the most sensitive polarity.
- c. The time interval between two successive single discharges was at least 1 second.
- d. The ESD generator was held perpendicularly to the surface to which the discharge was applied and the return cable was at least 0.2 meters from the EUT.
- e. Contact discharges were applied to the non-insulating coating, with the pointed tip of the generator penetrating the coating and contacting the conducting substrate.
- f. Air discharges were applied with the round discharge tip of the discharge electrode approaching the EUT as fast as possible (without causing mechanical damage) to touch the EUT. After each discharge, the ESD generator was removed from the EUT and re-triggered for a new single discharge. The test was repeated until all discharges were complete.
- g. At least ten single discharges (in the most sensitive polarity) were applied to the **Horizontal Coupling Plane** at points on each side of the EUT. The ESD generator was positioned horizontally at a distance of 0.1 meters from the EUT with the discharge electrode touching the **HCP**.
- h. At least ten single discharges (in the most sensitive polarity) were applied to the center of one vertical edge of the **Vertical Coupling Plane** in sufficiently different positions that the four faces of the EUT were completely illuminated. The **VCP** (dimensions 0.5m x 0.5m) was placed vertically to and 0.1 meters from the EUT.

### 5.4.4 DEVIATION FROM TEST STANDARD

No deviation.

### 5.4.5 TEST SETUP

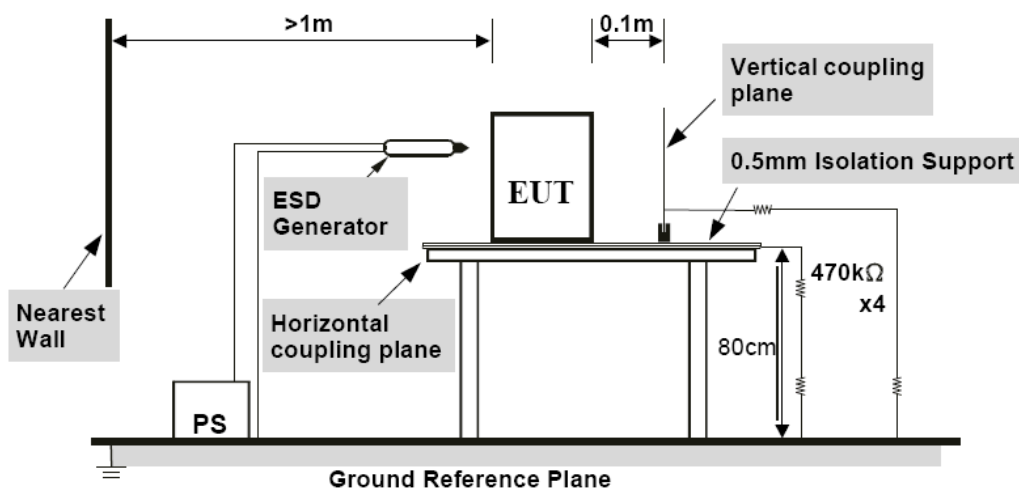

For the actual test configuration, please refer to the related item – Photographs of the Test Configuration.

**NOTE:**

TABLE-TOP EQUIPMENT

The configuration consisted of a wooden table 0.8 meters high standing on the **Ground Reference Plane**. The **GRP** consisted of a sheet of aluminum at least 0.25mm thick, and 2.5 meters square connected to the protective grounding system. A **Horizontal Coupling Plane** (1.6m x 0.8m) was placed on the table and attached to the **GRP** by means of a cable with 940kΩ total impedance. The equipment under test, was installed in a representative system as described in section 7 of EN 61000-4-2, and its cables were placed on the **HCP** and isolated by an insulating support of 0.5mm thickness. A distance of 1-meter minimum was provided between the EUT and the walls of the laboratory and any other metallic structure.

## 5.4.6 TEST RESULTS

Input Power	230 Vac, 50 Hz	Test Date	2014/11/27
Environmental Conditions	22 °C, 53% RH 988 mbar	Tested by	Leo Chan

Test Results of Direct Application					
Discharge Level (kV)	Polarity (+/-)	Test Point	Contact Discharge	Air Discharge	Performance Criterion
2, 4	+/-	1-7	Note 1	NA	A
6	+/-	1-7	Note 2	NA	B
2	+/-	8	Note 1	NA	A
4, 6	+/-	8	Note 3	NA	B
2, 4, 8	+/-	9	NA	Note 1	A
2, 4	+/-	10-11	NA	Note 1	A
8	+/-	10-11	NA	Note 2	B
2, 4	+/-	12	NA	Note 1	A
8	+/-	12	NA	Note 3	B

Description of test points of direct application: Please refer to following page for representative mark only.

Test Results of Indirect Application					
Discharge Level (kV)	Polarity (+/-)	Test Point	Horizontal Coupling Plane	Vertical Coupling Plane	Performance Criterion
2, 4, 6	+/-	Four Sides	Note 1	Note 1	A

Description of test points of indirect application:

1. Front side                      2. Rear side                      3. Right side                      4. Left side

- Note: 1. The EUT function was correct during the test.  
 2. The EUT USB HDD R/W function held during the test, but could self-recover after the test.  
 3. The LAN PING had request time out message during the test, but could self-recover after the test.



### Description of Test Points

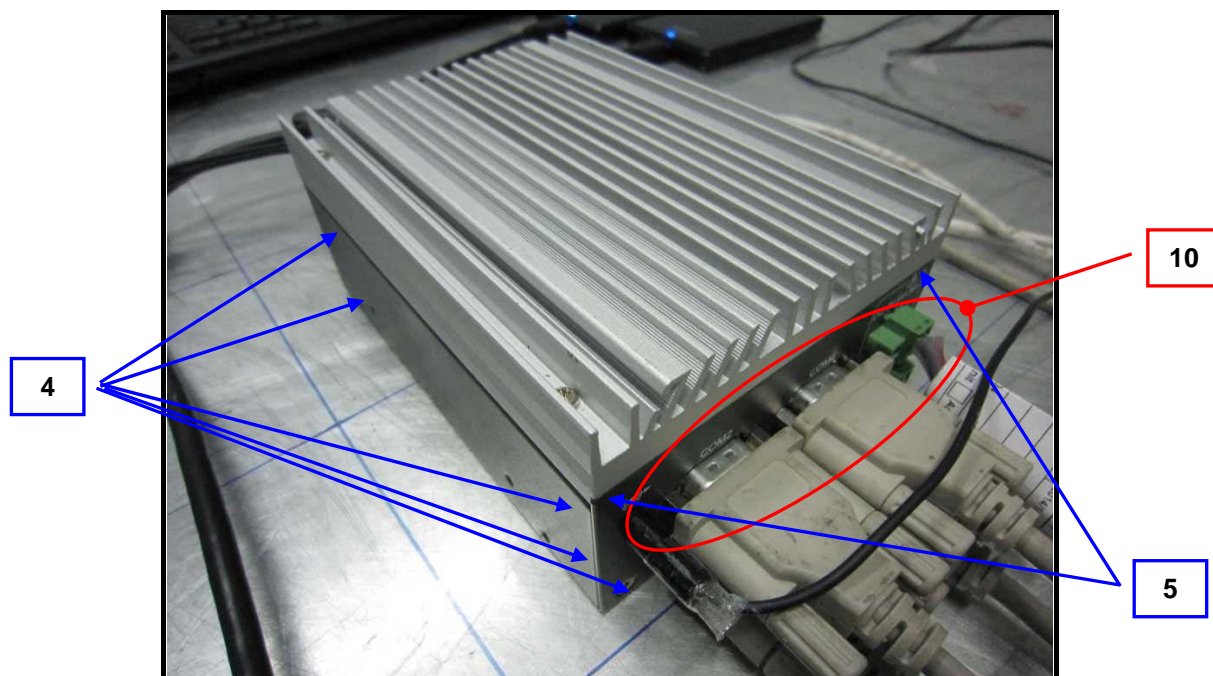
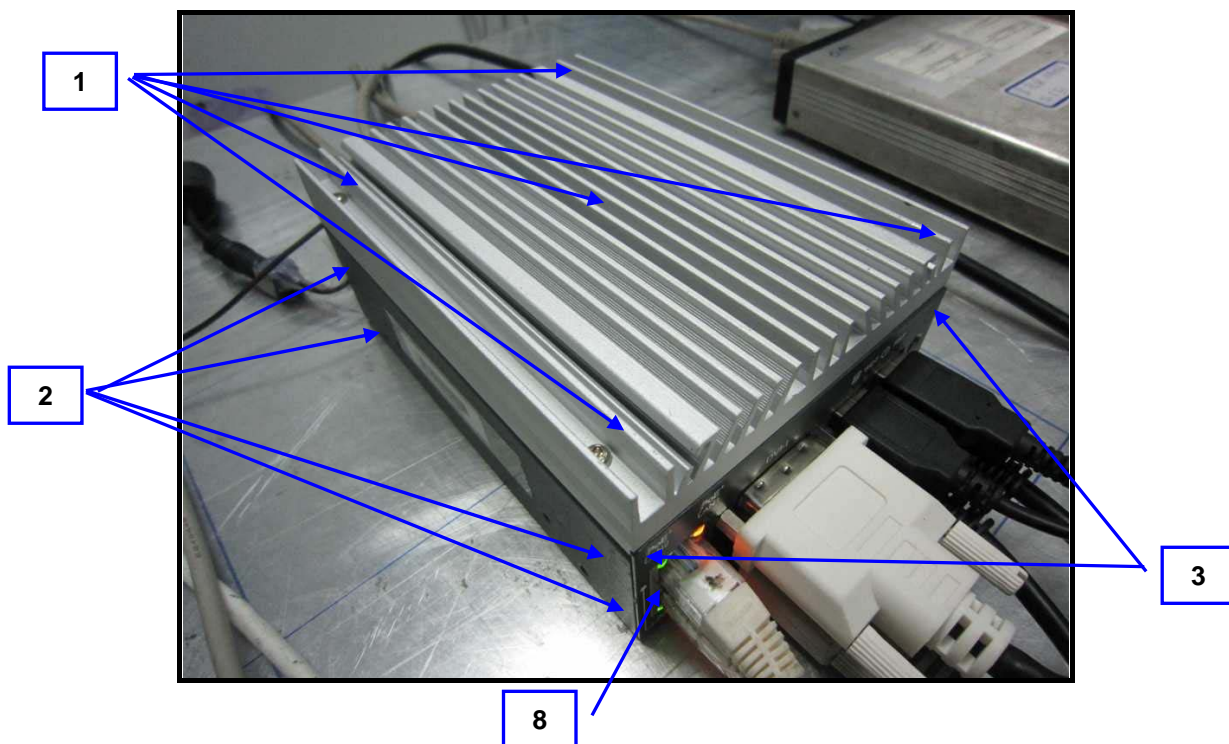

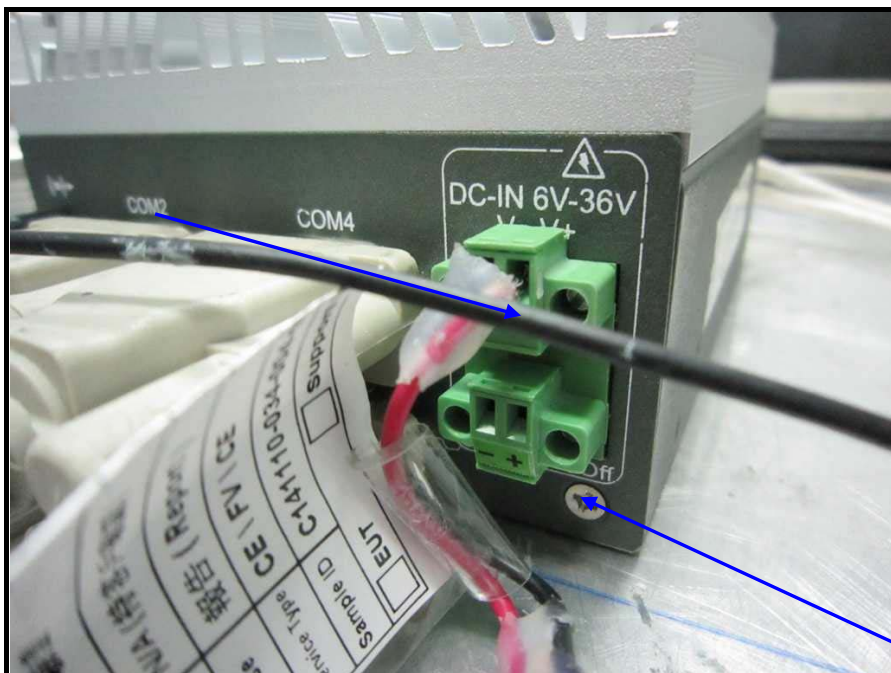

6

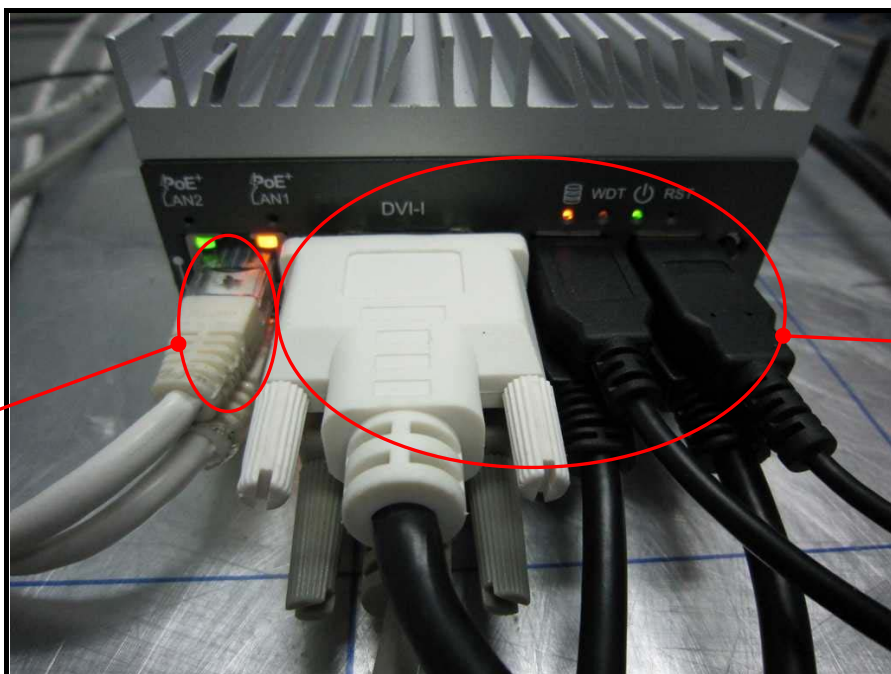

12

11

7

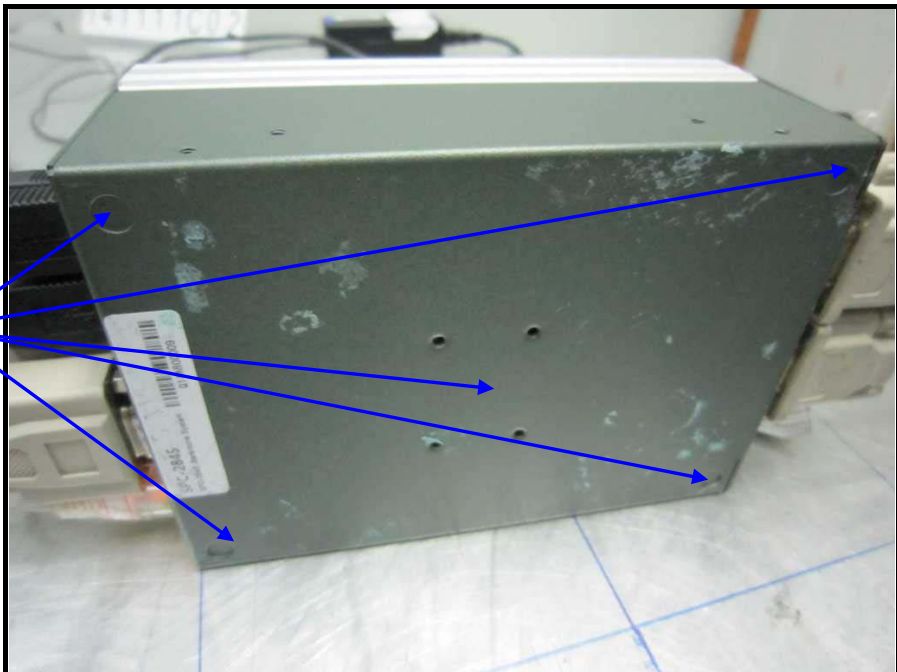

9

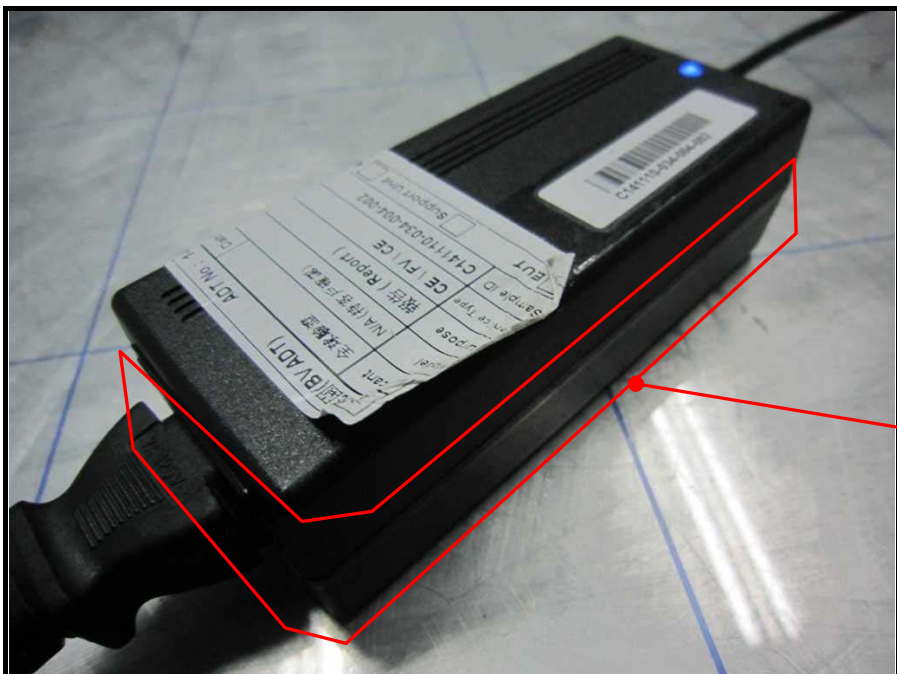

## 5.5 RADIATED, RADIO-FREQUENCY, ELECTROMAGNETIC FIELD IMMUNITY TEST (RS)

### 5.5.1 TEST SPECIFICATION

<b>Basic Standard:</b>	EN 61000-4-3
<b>Frequency Range:</b>	80 MHz ~ 1000 MHz, 800 MHz ~ 1000 MHz, 1400 MHz ~ 2100 MHz, 2100 MHz ~ 2500 MHz
<b>Field Strength:</b>	20 V/m, 20 V/m, 10 V/m, 5 V/m
<b>Modulation:</b>	1 kHz Sine Wave, 80%, AM Modulation
<b>Frequency Step:</b>	1 % of preceding frequency value
<b>Polarity of Antenna:</b>	Horizontal and Vertical
<b>Antenna Height:</b>	1.55 m
<b>Dwell Time:</b>	3 seconds

### 5.5.2 TEST INSTRUMENTS

Description & Manufacturer	Model No.	Serial No.	Cal. Date	Cal. Due
BONN Power Amp	BLMA 1060-100/50D	118694	NA	NA
BBA Power Amp	B250C125	101011	NA	NA
Power Sensor	NRP-Z91	101572	Jan. 22, 2014	Jan. 21, 2015
Power Sensor	NRP-Z91	101573	Jan. 22, 2014	Jan. 21, 2015
Signal Generator	SMB100A	105801	Jan. 16, 2014	Jan. 15, 2015
R&S Software	EMC32 Version 8.52.0	NA	NA	NA
Stacked Log-Per Antenna	STLP9149	9149-141	NA	NA
High GAIN LOG-Periodic Antenna	HL046E	100114	NA	NA

- Notes: 1. The test was performed in Hwa Ya RS Room 2.  
 2. The calibration interval of the above test instruments is 12 months and the calibrations are traceable to NML/ROC and NIST/USA.  
 3. The transmit antenna was located at a distance of 3 meters from the EUT.

### 5.5.3 TEST PROCEDURE

The test procedure was in accordance with EN 61000-4-3.

- a. The testing was performed in a modified semi-anechoic chamber.
- b. The frequency range is swept 80 MHz ~ 1000 MHz, 800 MHz ~ 1000 MHz, 1400 MHz ~ 2100 MHz, 2100 MHz ~ 2500 MHz, with the signal 80% amplitude modulated with a 1 kHz sinewave.
- c. The dwell time at each frequency shall not be less than the time necessary for the EUT to be exercised and to respond, but shall in no case be less than 0.5s.
- d. The field strength level was 20V/m, 20V/m, 10V/m, 5V/m.
- e. The test was performed with the EUT exposed to both vertically and horizontally polarized fields on each of the four sides.

### 5.5.4 DEVIATION FROM TEST STANDARD

No deviation.

### 5.5.5 TEST SETUP

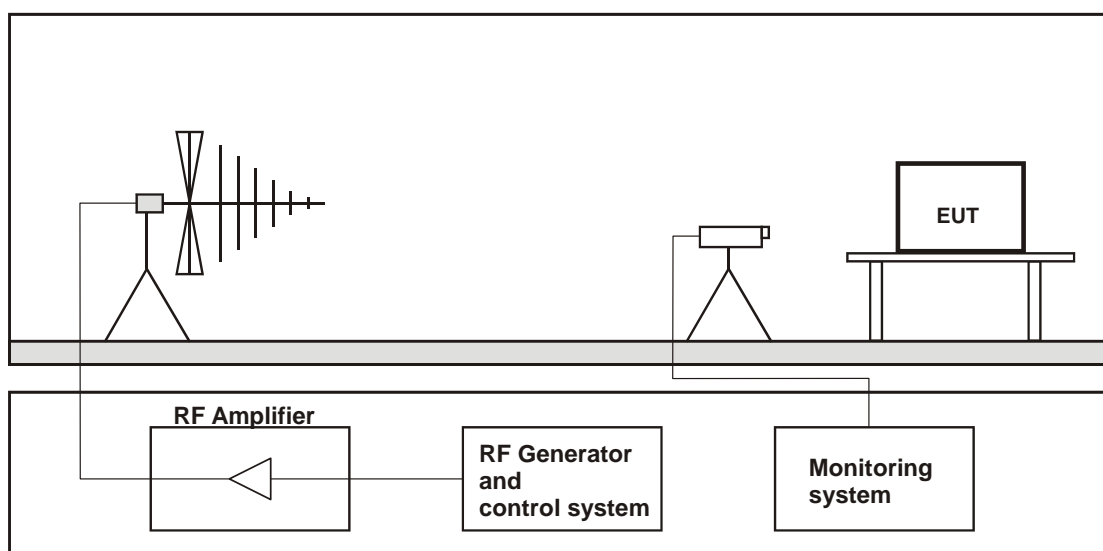

For the actual test configuration, please refer to the related item – Photographs of the Test Configuration.

#### **NOTE:**

#### **TABLETOP EQUIPMENT**

The EUT installed in a representative system as described in section 7 of EN 61000-4-3 was placed on a non-conductive table 0.8 meters in height. The system under test was connected to the power and signal wire according to relevant installation instructions.

### 5.5.6 TEST RESULTS

Input Power	230 Vac, 50 Hz	Test Date	2015/1/7
Environmental Conditions	25 °C, 55% RH	Tested by	Vincent Yang

Frequency (MHz)	Polarity	Azimuth(°)	Applied Field Strength (V/m)	Test Distance (m)	Observation	Performance Criterion
80-1000	V&H	0, 90, 180, 270	20	1.75	Note 1	A
800-1000	V&H	0, 90, 180, 270	20	1.75	Note 1	A
1400-2100	V&H	0, 90, 180, 270	10	3	Note 1	A
2100-2500	V&H	0, 90, 180, 270	5	3	Note 1	A

\*The EUT was tested with ground cable.

Note: 1. The EUT function was correct during the test.

## 5.6 ELECTRICAL FAST TRANSIENT (EFT)

### 5.6.1 TEST SPECIFICATION

<b>Basic Standard:</b>	EN 61000-4-4
<b>Test Voltage:</b>	Power Line: 2 kV Signal line: 2 kV
<b>Polarity:</b>	Positive & Negative
<b>Impulse Frequency:</b>	5 kHz
<b>Impulse Waveshape:</b>	5/50 ns
<b>Burst Duration:</b>	15 ms
<b>Burst Period:</b>	300 ms
<b>Test Duration:</b>	1 min.

### 5.6.2 TEST INSTRUMENT

Description & Manufacturer	Model No.	Serial No.	Cal. Date	Cal. Due
EMC-Partner EFT Generator	TRA2000EFT-C1	623	May 16, 2014	May 15, 2015
EMC-Partner Capacitive Coupling clamp	CN-EFT1000	364	May 16, 2014	May 15, 2015
EFT Adapter WONPRO	WA	EF1Ada-001	NA	NA
Software	EMC-Partner GENECS	NA	NA	NA

Notes: 1. The test was performed in Hwa Ya EFT Room 1.  
2. The calibration interval of the above test instruments is 12 months and the calibrations are traceable to NML/ROC and NIST/USA.

### 5.6.3 TEST PROCEDURE

- Both positive and negative polarity discharges were applied.
- The distance between any coupling devices and (0.5 – 0/+0.1) m for table-top equipment testing, and (1.0 ± 0.1) m for floor standing equipment
- The duration time of each test sequential was 1 minute.
- The transient/burst waveform was in accordance with EN 61000-4-4, 5/50ns.

## 5.6.4 DEVIATION FROM TEST STANDARD

No deviation.

## 5.6.5 TEST SETUP

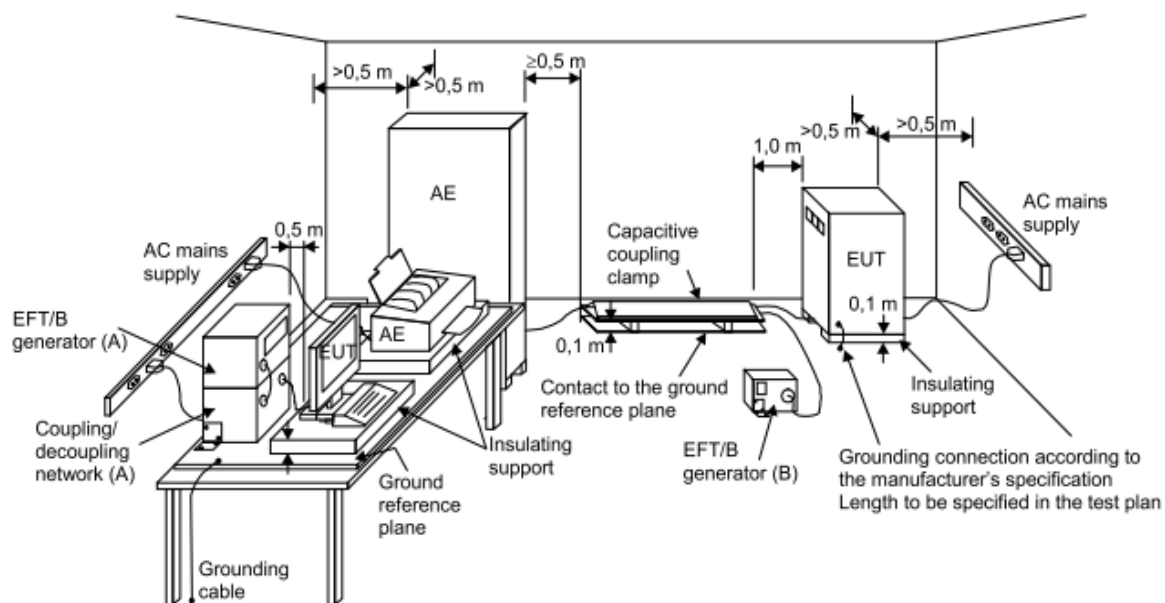

IEC 645/12

### NOTE:

- (A) location for supply line coupling
- (B) location for signal lines coupling

For the actual test configuration, please refer to the related item – Photographs of the Test Configuration.



### 5.6.6 TEST RESULTS

Input Power	230 Vac, 50 Hz	Test Date	2014/12/21
Environmental Conditions	23 °C, 56% RH	Tested by	Andy Chang

#### Power port

Voltage (kV)	Test Point	Polarity (+/-)	Observation	Performance Criterion
2	L1	+/-	Note 1	A (Judged by manufacturer)
2	L2	+/-	Note 1	
2	L1-L2	+/-	Note 1	
2	PE	+/-	Note 1	
2	L1-PE	+/-	Note 1	
2	L2-PE	+/-	Note 1	
2	L1-L2-PE	+/-	Note 1	

#### Signal port

Voltage (kV)	Test Point	Polarity (+/-)	Observation	Performance Criterion
2	LAN 1	+/-	Note 1	A (Judged by manufacturer)
2	LAN 2	+/-	Note 1	

\*The EUT was tested with ground cable.

Note: 1. The earphone had beep during the test, but could self-recover after the test.

## 5.7 SURGE IMMUNITY

### 5.7.1 TEST SPECIFICATION

<b>Basic Standard:</b>	EN 61000-4-5
<b>Wave-Shape:</b>	Combination Wave 1.2/50 $\mu$ s Open Circuit Voltage 8/20 $\mu$ s Short Circuit Current 1.2/50 $\mu$ s Wave for signal lines 8/20 $\mu$ s Short Circuit Current
<b>Test Voltage:</b>	Power Line: 0.5, 1, 2 kV Signal Line: NA
<b>Polarity:</b>	Positive/Negative
<b>Phase Angle:</b>	0° /90°/180°/270°
<b>Pulse Repetition Rate:</b>	1 time / 60 sec.
<b>Number of Tests:</b>	5 positive and 5 negative at selected points

### 5.7.2 TEST INSTRUMENT

Description & Manufacturer	Model No.	Serial No.	Cal. Date	Cal. Due
Modular Impulse Generator EMC-Partner	MIG0603IN3	352	Sep. 02, 2014	Sep. 01, 2015
Universal Surge Coupling De-Coupling Network EMC-Partner	CDN UTP8	011	Sep. 02, 2014	Sep. 01, 2015
Surge Adapter WONPRO	WA	SU1 Ada-001	NA	NA
Coupling and Decoupling Network EMC PARTNER	CDN2000 06 32	093	NA	NA

- Notes: 1. The test was performed in Hwa Ya Surge Room 2.  
2. The calibration interval of the above test instruments is 12 months and the calibrations are traceable to NML/ROC and NIST/USA.

### 5.7.3 TEST PROCEDURE

a. For EUT power supply:

The surge is to be applied to the EUT power supply terminals via the capacitive coupling network. Decoupling networks are required in order to avoid possible adverse effects on equipment not under test that may be powered by the same lines, and to provide sufficient decoupling impedance to the surge wave. The power cord between the EUT and the coupling/decoupling networks shall be 2 meters in length (or shorter).

For double-insulated products without PE or external earth connections, the test shall be done in a similar way as for grounded products but without adding any additional external grounded connections. If there are no other possible connections to earth, line-to-ground tests may be omitted.

b. For test applied to unshielded unsymmetrically operated interconnection lines of EUT:

The surge is applied to the lines via the capacitive coupling. The coupling / decoupling networks shall not influence the specified functional conditions of the EUT. The interconnection line between the EUT and the coupling/decoupling networks shall be 2 meters in length (or shorter).

c. For test applied to unshielded symmetrically operated interconnection / telecommunication lines of EUT:

The surge is applied to the lines via gas arrestors coupling. Test levels below the ignition point of the coupling arrestor cannot be specified. The interconnection line between the EUT and the coupling/decoupling networks shall be 2 meters in length (or shorter).

### 5.7.4 DEVIATION FROM TEST STANDARD

No deviation.

### 5.7.5 TEST SETUP

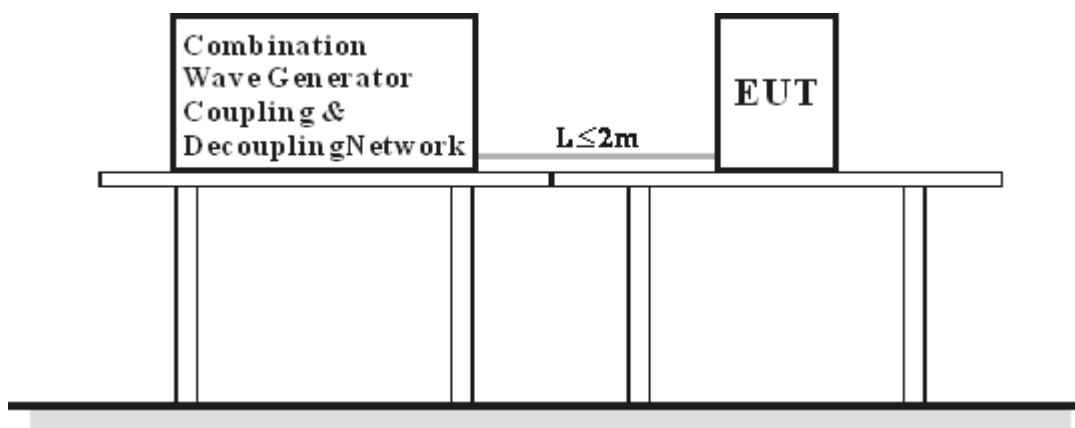

For the actual test configuration, please refer to the related item – Photographs of the Test Configuration.

### 5.7.6 TEST RESULTS

Input Power	230 Vac, 50 Hz	Test Date	2014/11/29
Environmental Conditions	23 °C, 53% RH	Tested by	Davis Chen

#### Power port

Voltage (kV)	Test Point	Polarity (+/-)	Observation	Performance Criterion
0.5, 1	L1-L2	+/-	Note 1	A
0.5, 1, 2	L1-PE	+/-	Note 1	A
0.5, 1, 2	L2-PE	+/-	Note 1	A

Note: 1. The EUT function was correct during the test.

## 5.8 CONDUCTED RADIO FREQUENCY DISTURBANCES (CS)

### 5.8.1 TEST SPECIFICATION

<b>Basic Standard:</b>	EN 61000-4-6
<b>Frequency Range:</b>	0.15 MHz ~ 80 MHz
<b>Voltage Level:</b>	10 Vrms
<b>Modulation:</b>	1kHz Sine Wave, 80%, AM Modulation
<b>Frequency Step:</b>	1 % of preceding frequency value
<b>Dwell Time:</b>	3 seconds

## 5.8.2 TEST INSTRUMENT

Description & Manufacturer	Model No.	Serial No.	Cal. Date	Cal. Due
FCC POWER LINE COUPLING DECOUPLING NETWORK	FCC-801-M1-25A	03030	May 22, 2014	May 21, 2015
FCC POWER LINE COUPLING DECOUPLING NETWORK	FCC-801-M2-25A	03049	Nov. 07, 2014	Nov. 06, 2015
FCC POWER LINE COUPLING DECOUPLING NETWORK	FCC-801-M2-25A	03050	Nov. 07, 2014	Nov. 06, 2015
FCC POWER LINE COUPLING DECOUPLING NETWORK	FCC-801-M3-25A	03056	Nov. 07, 2014	Nov. 06, 2015
FCC POWER LINE COUPLING DECOUPLING NETWORK	FCC-801-M3-25A	03057	Nov. 07, 2014	Nov. 06, 2015
FCC SIGNAL LINE POWER LINE COUPLING DECOUPLING NETWORK	FCC-801-T2	03030	Nov. 07, 2014	Nov. 06, 2015
FCC SIGNAL LINE POWER LINE COUPLING DECOUPLING NETWORK	FCC-801-T4	03031	Nov. 07, 2014	Nov. 06, 2015
FCC SIGNAL LINE POWER LINE COUPLING DECOUPLING NETWORK	FCC-801-T8	03032	Nov. 07, 2014	Nov. 06, 2015
EMI Injection Clamp	F2031-23MM	434	Nov. 07, 2014	Nov. 06, 2015
Amplifier Research Power Amplifier	75A250AM2	307804	NA	NA
BOONTON 4232ARF POWER METER	4232A-01-02	104302	Nov. 14, 2014	Nov. 13, 2015
R&S Signal Generator	SML01	102148	Nov. 14, 2014	Nov. 13, 2015
Software	ADT_CS_V37	NA	NA	NA
POWER SENSOR	51011-EMC	30028	Nov. 14, 2014	Nov. 13, 2015
POWER SENSOR	51011-EMC	33029	Nov. 14, 2014	Nov. 13, 2015

- Notes: 1. The test was performed in Hwa Ya CS Room 1.  
 2. The calibration interval of the above test instruments is 12 months and the calibrations are traceable to NML/ROC and NIST/USA.

### 5.8.3 TEST PROCEDURE

- a. The EUT shall be tested within its intended operating and climatic conditions.
- b. An artificial hand was placed on the hand-held accessory and connected to the ground reference plane.
- c. One of the CDNs not used for injection was terminated with  $50\Omega$ , providing only one return path. All other CDNs were coupled as decoupling networks.
- d. The frequency range is swept from 150 kHz to 80 MHz, using the signal level established during the setting process and with a disturbance signal of 80 % amplitude. The signal is modulated with a 1 kHz sine wave, pausing to adjust the RF signal level or the switch coupling devices as necessary. Where the frequency is swept incrementally, the step size shall not exceed 1% of the preceding frequency value.
- e. The dwell time of the amplitude modulated carrier at each frequency shall not be less than the time necessary for the EUT to be exercised and to respond, but shall in no case be less than 0.5 s. The sensitive frequencies (e.g. clock frequencies) shall be analyzed separately.
- f. Attempts should be made to fully exercise the EUT during testing, and to fully interrogate all exercise modes selected for susceptibility.

### 5.8.4 DEVIATION FROM TEST STANDARD

No deviation.

## 5.8.5 TEST SETUP

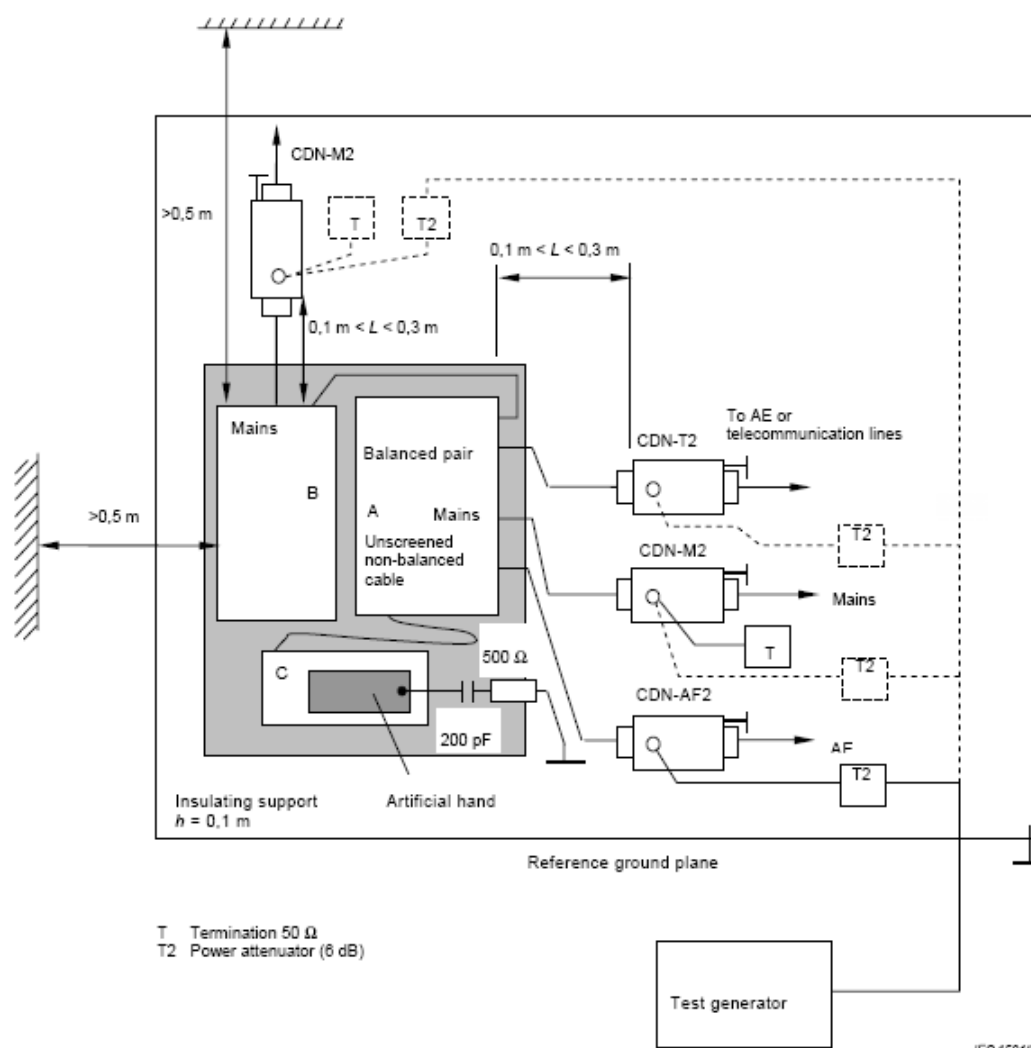

- Note:** 1. The EUT clearance from any metallic obstacles shall be at least 0.5 m.  
2. Interconnecting cables ( $\leq 1$  m) belonging to the EUT shall remain on the insulating support.

For the actual test configuration, please refer to the related item – Photographs of the Test Configuration.

### NOTE:

The equipment to be tested is placed on an insulating support of 0.1 meters height above a ground reference plane. All relevant cables shall be provided with the appropriate coupling and decoupling devices at a distance between 0.1 meters and 0.3 meters from the projected geometry of the EUT on the ground reference plane.



### 5.8.6 TEST RESULTS

Input Power	230 Vac, 50 Hz	Test Date	2014/12/1
Environmental Conditions	23 °C, 58% RH	Tested by	Davis Chen

Frequency (MHz)	Level (Vrms)	Tested Line	Injection Method	Return Path	Observation	Performance Criterion
0.15 – 80	10	Power	CDN-M3	EM-Clamp	Note 1	A
0.15 – 80	10	LAN 1	EM-Clamp	CDN-M3	Note 1	A
0.15 – 80	10	LAN 2	EM-Clamp	CDN-M3	Note 1	A

Note: 1. The EUT function was correct during the test.

## 6 PHOTOGRAPHS OF THE TEST CONFIGURATION

### Conducted Emissions Test

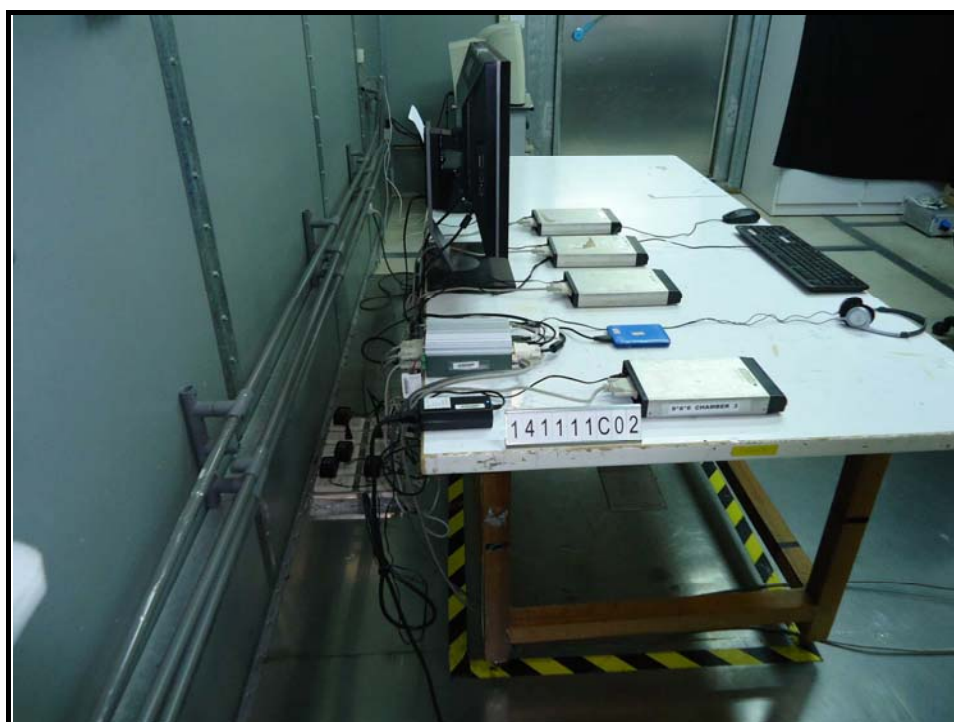

### Radiated Emissions Test



### ESD Test



### RS Test



### EFT Test - Mains ports



### EFT Test - Signal ports



### Surge Test - Mains ports



### CS Test - Mains ports



### CS Test - Signal ports





A D T

## 7 INFORMATION ON THE TESTING LABORATORIES

We, Bureau Veritas Consumer Products Services (H.K.) Ltd., Taoyuan Branch, were founded in 1988 to provide our best service in EMC, Radio, Telecom and Safety consultation. Our laboratories are accredited and approved according to ISO/IEC 17025.

If you have any comments, please feel free to contact us at the following:

**Linko EMC/RF Lab**

Tel: 886-2-26052180

Fax: 886-2-26051924

**Hsin Chu EMC/RF/Telecom Lab**

Tel: 886-3-5935343

Fax: 886-3-5935342

**Hwa Ya EMC/RF/Safety Lab**

Tel: 886-3-3183232

Fax: 886-3-3270892

**Email:** [service.adt@tw.bureauveritas.com](mailto:service.adt@tw.bureauveritas.com)

**Web Site:** [www.bureauveritas-adt.com](http://www.bureauveritas-adt.com)

The address and road map of all our labs can be found in our web site also.

--- END ---